

Flanking paths associated with exposed roof decks in condominiums

Jeffrey P. Kwoikoski^{a)}
D. L. Adams Associates, Inc.
1701 Boulder Street
Denver, CO 80211

An award winning residential/commercial condominium project featured two-story loft condominiums with an industrial look. The building was constructed with exposed steel structure, concrete floors, and an exposed metal deck roof. Condominiums were separated by gypsum board metal stud walls. A number of owners in the building complained of poor sound isolation from adjacent units. Field tests showed that sound isolation of the walls fell well below expectations for the design. Subsequent investigation showed that a variety of structureborne and airborne flanking paths contributed to poor sound isolation. Improving sound isolation required a combination of conventional and creative methods.

1 INTRODUCTION

A multi-use building project featured 44 one and two bedroom “live-work” condominiums. The first and second floors of the building were occupied with commercial business space. The two story live-work units occupied the third and fourth floor of the four story building. The loft style units included a kitchen, bathroom, and live-work space on the main floor, with a smaller mezzanine/loft area that was open to below. The condominium units had an industrial look with exposed metal roof deck, concrete floors, exposed structural beams, and exposed mechanical ductwork and electrical conduit.

Some of the condominiums were used as a residence, some were used for business, and some were used for both. Most of the business uses were relatively quiet businesses such as architecture offices, artist studios, and other professional offices. After many of the units became occupied, the developer started to hear complaints from owners and occupants about sound isolation. Residents and tenants complained of hearing conversations, phones ringing, music, and other sounds from neighboring units.

^{a)} Email address: jkwoikoski@dlaa.com

2 EXISTING CONDITIONS

Our firm became involved at this point on behalf of the general contractor to subjectively evaluate the existing conditions. All of the sound complaints were from the live-work units and of sound coming from a next-door unit on the same floor. There no complaints of sounds coming from units below. There were no complaints of sound transfer between first or second floor businesses.

2.1 Wall Construction

Before visiting the site, we evaluated the demising wall construction. According to the drawings and statements from the general contractor, the demising wall consisted of one layer of 16 mm (5/8") gypsum board on one side, and two layers of 16mm (5/8") gypsum board on the other side of 203 mm (8") deep 20 gauge metal studs, placed 406 mm (16") on center. The stud cavity was filled with fiberglass batt insulation. The gypsum board on one side of the wall was mounted on 12 mm (1/2") resilient channels. The total wall thickness was 251 mm (9-7/8"). Please refer to **Figure 1** for the wall construction. We estimated the wall's Sound Transmission Class (STC) to be approximately 58. We would not expect the complaints that the owner was receiving if the wall was built properly and there were minimal sound flanking paths.

2.2 Leaks and Flanking Paths

A sound flanking path is defined as a path that sound travels from one side of a wall to the other without passing directly *through* the wall.

During our first visit to the building we subjectively evaluated the sound isolation between two condominiums. I listened while someone spoke in the adjacent unit. I could hear the voice and understand occasional words. When music was played over a stereo system, I could clearly hear the music and understand the vocals. Subjectively, the sound that I heard was much clearer than I would expect through an STC 58 wall, so we knew that sound must be flanking around the wall.

I was able to use a ladder to observe the top of the wall near the metal roof deck. Sound appeared to be coming from a horizontal 305 mm (12") steel stud that penetrated the wall against the underside of the roof deck at the exterior wall. Refer to **Figure 2** for a photograph of this condition.

The contractor indicated that the horizontal stud served as bracing during construction. There was no gypsum board behind the stud (between the stud and the roof deck). The stud was no longer needed structurally, however, the stud was an integral part of the appearance of the units now and could not be removed to seal the hole in the gypsum board.

The joint between the top of the wall and the metal roof deck was caulked, but the caulk had cracked in many places and no longer provided an airtight seal. Sound was likely leaking through this joint. Refer to **Figure 3** for a photograph. There was no caulk between the bottom of the wall and the concrete floor slab.

We suspected, from previous experience, that sound was likely flanking through the exposed roof deck, but it was difficult to estimate to what extent. At this point the contractor was reluctant to authorize objective tests, and his approach would be to seal the most obvious sound leaks first to see if the improvement was sufficient.

2.3 Airborne Sound Flanking Repairs

The hole in the gypsum board at the horizontal stud penetration, on each side of the demising wall, was approximately 305 mm (12") wide by 76mm (3") high. The gypsum board was tight all around the stud, but it did not fill inside the "C" shape of the stud. The hole was not easily accessible. We considered various methods to attempt to fill the holes with expanding foam, grout, caulk, and other materials, but could not be confident that the hole would be completely filled and sealed.

The sound was traveling into the stud on one side of the wall, laterally through the stud and through the hole in the wall, and then out the exposed stud on the other side of the wall. We decided that the most reliable solution was to wrap the horizontal stud within a unit, from the demising wall on one side to the demising wall on the other side.

First, fiberglass batt insulation was stuffed into the stud (through holes in the stud) as much as possible within about one meter of each side of the wall to provide sound absorption inside the stud cavity. Then the stud was covered with cellulose fiberboard to add mass to the sound barrier on each side of the wall. The fiberboard was fastened directly to the underside of the stud. Finally, the fiberboard was covered with sheet metal for aesthetic purposes. Refer to **Figure 4** for the detail. This detail was implemented in two side-by-side condominiums.

The joint at the top of the wall was recaulked on each side. The joint at the floor was caulked on both sides.

After this work, the sound isolation between the two units was subjectively evaluated. The sound audible from the adjacent unit was noticeably reduced. While music from a stereo playing in the neighboring unit was still audible, the vocals were no longer intelligible. Nonetheless, after evaluation by the unit owners, the improvement was not judged to be sufficient.

3 TESTING

At this point, the contractor decided to proceed with objective testing to measure the sound isolation between units.

The 2003 International Building Code (IBC) set the minimum requirements for airborne and impact sound isolation in this municipality for multi-family buildings. Section 1207 requires that walls and floor-ceilings that separate residential units from other units and from public spaces have a Sound Transmission Class (STC) of 50 or greater. If field tested, the field rating must be 45 or greater. The design of the wall itself met the STC 50 requirement, but the testing would assess the field performance.

All tests were performed in accordance with ASTM E 336-07 *Standard Test Method for Measurement of Airborne Sound Attenuation between Rooms in a Building*. The Apparent Sound Transmission Class (ASTC) was determined in accordance with ASTM E 413 *Classification for Rating Sound Insulation*.

3.1 First Test

In July of 2008, a test was performed on one demising wall between units. The intent of the test was to determine the ASTC and evaluate additional flanking paths, including the roof

deck. The ASTC was 41. Refer to the “ASTC 41” curve in **Figure 5** for the test results, and refer to **Figure 6** for the floor plan of the two units. The ASTC rating was limited by the large dip in sound Transmission Loss at 630 Hz and 800 Hz.

The ASTC 41 rating was well below the design rating of STC 58. The ASTC 58 rating requires properly designed and installed resilient channels. However, the resilient channels would have to be completely ineffective to account for the ASTC 41 rating, and the dip in Transmission Loss at 800 Hz was not typical of resilient channel problems. The obvious airborne flanking paths and leaks noted during our first visit had already been remedied before the ASTC test. Based on the test results, it appeared that significant flanking paths still existed.

Subjectively, the strongest sounds during the ASTC test seemed to be coming from the roof deck. Past experience had shown that structureborne sound flanking through exposed metal roof decks (with only a lightweight roof system above) can be significant. We felt that flanking through the metal deck was the dominant sound path. Any remedial work to the roof deck would be quite expensive. After discussing this with the contractor, we decided to perform another test to help confirm our suspicions that the metal deck was indeed the dominant sound path.

3.2 Second Test

First, a second layer of 16 mm gypsum board was installed on one side of the test wall. The wall now consisted of two layers of gypsum board on each side of the 203 mm studs. If the direct sound path through the wall was the dominant path, then the ASTC rating should increase by three to four ASTC points.

A second ASTC test was performed. The ASTC test result was 42. The ASTC increased by one point. Sound transmission loss increased somewhat below 250 Hz and above 800 Hz, but the ASTC was still limited by the dip at 630 Hz and 800 Hz. Please refer to the “ASTC 42” curve in Figure 5. Subjectively, the strongest sound appeared to be coming from the roof deck. Sound was audible in the exterior wall to a lesser degree.

During the ASTC testing, vibration was measured on several surfaces on the receiving side of the test wall while pink noise was generated at high levels on the source side. A Larson Davis 2900 real time analyzer was used together with a Brüel & Kjær Type 4370 54 gram accelerometer to measure vibration levels in one-third octave bands and narrow bands. The vibration levels were averaged over 30-second durations. Acceleration was measured on the demising wall, on the exposed roof deck at a location 914 mm (36") from the wall, on the concrete floor, and on the exterior wall. The measured acceleration levels are plotted in **Figure 7**.

The “deck” measurement was taken on the upper flat portion of the deck (the highest point). The “rib” measurement was on the rib of the deck (the lowest point). Note that the “rib” acceleration levels peak at 800 Hz, while the “deck” measurements peak at 400 Hz. The rib vibration correlated much closer to the dip in Apparent Transmission Loss evident in the ASTC tests. The acceleration levels on the walls and floor at 630 Hz and 800 Hz were more than 15 decibels below the levels on the roof deck ribs.

The vibration peak at 800 Hz on the rib of the roof deck correlated to the dip in apparent transmission loss in the ASTC test results. Using the acceleration levels on the deck, we estimated the sound pressure level in the room that should be expected from the acceleration levels on the roof deck.² We estimated a sound pressure level of approximately 55 decibels at 630 Hz and 800 Hz. The ASTC receiving room measurements made simultaneously with the vibration measurements were 55 and 55 decibels at 630 Hz and 800 Hz, respectively. We now

had a good indication that structureborne flanking through the roof deck would need to be addressed in order to achieve an ASTC 45 between condominiums.

The sound levels at 315 Hz and 400 Hz did not correlate well with predictions using the same methodology. We speculate that the deck is a less efficient sound radiator at these frequencies.

4 POTENTIAL SOLUTIONS

Based on the results of our ASTC tests, vibration measurements, and subjective observations, we were directed by our client to develop methods to improve the ASTC rating to 45.

4.1 Airborne Flanking and Leaks

The measures already taken on the test wall to eliminate the airborne flanking and leaks would be implemented for every demising wall. The bottom of the wall would be caulked at the floor. The sealant would be redone at the head of the wall. The horizontal stud near the exterior wall would be covered. The additional layer of gypsum board that had been added was removed from the wall and would not be implemented for other walls as there was little benefit for what would be considerable cost.

4.2 Roof Deck Flanking

From the first ASTC test plot, it was clear that if the dip at 630 Hz and 800 Hz could be eliminated, the wall should yield an ASTC 45 or better. Refer to the illustration in **Figure 8**. The challenge was how to achieve this.

The roof system was an EPDM adhered roof system on 16 mm (5/8") fiberglass mat-faced gypsum board, over 152 mm (6") rigid foam insulation, on the metal roof deck. The metal roof deck was 76 mm (3") deep 18 gauge composite metal deck.

We first considered a surface applied damping compound on the underside of the roof deck. Applying the damping compound to all or most of the exposed metal deck would be messy and very intrusive to the occupants of the units. Furnishings would have to be covered, and odor was a potential issue. Aesthetically, it would alter the appearance of the building.

A second consideration, and proven solution,¹ was to remove the roof system, pour concrete on the metal deck, and replace the roof system. This was not a feasible option as the building structure would not support the additional weight of concrete.

A gypsum board ceiling fastened to the underside of the metal deck was also considered. A ceiling was perhaps the most desirable option from an acoustic standpoint. A ceiling could be designed to mitigate the sound radiating from the metal deck, and it would also cover any gaps or leaks at the ceiling and at the metal deck joints. It could be designed to cover the horizontal studs. Aesthetically, a ceiling was not considered a viable option. Many buyers had purchased their units in large part because of the industrial look and feel, and a gypsum board ceiling was not acceptable.

Although concrete over the entire roof deck was not feasible, the structural engineer indicated that a small strip of concrete directly over the load-bearing demising walls was feasible. The narrow strip of concrete was not going to be as effective as covering all or most of the roof deck¹, and predicting the improvement that could be expected was difficult. However,

we felt that it should give some improvement, and only three to five decibels of improvement at 800 Hz was needed to raise the ASTC to 45 or better. We also expected that pouring the concrete would at least partially seal the joint between metal deck sections. Refer to **Figure 9** for an illustration of where the leaks occurred at the metal roof deck joints. If any sound was traveling over the wall through the hollow “channels” created between the deck flutes and the rigid insulation, the concrete strip would close this path as well. The concrete strip option was deemed the best option available and the contractor decided to try the approach over the test demising wall. See **Figure 10** for the detail that was used.

In September 2008, the roof was cut and a concrete strip was poured over one wall. Approximately one week later, the ASTC of the wall was measured to be ASTC 46 - an improvement of 4 points from ASTC 42. The plotted data is shown in **Figure 11**. The Apparent Transmission Loss was improved by 3 and 5 decibels at 630 Hz and 800 Hz, respectively.

Vibration levels were remeasured in the same locations. The results are shown in **Figure 12**. The acceleration level at 630 Hz and 800 Hz was reduced by 6 and 13 decibels, respectively.

After reviewing the test results, the client made the decision to retrofit the concrete strip on the roof over all of the demising walls. We advised the client that it was quite likely that some of the walls would fall short of the ASTC 45 requirement due to the normal variation in wall construction and building construction, and uncertainty in the test methods.

In October 2008, the concrete strip was installed over the remaining 39 walls. In the following months, six walls were tested. The results were ASTC 42, 44, 46, 46, 47, and 47. Despite the concrete on the roof, the ASTC values were either being limited by the ATL at 800 Hz, or were within one decibel of being limited. The results also showed some room for improvement at higher frequencies above 800 Hz. Since our client had committed to the building developer that all walls would be ASTC 45 or better, the walls below ASTC 45 required further improvement.

Further subjective investigation was done on the receiving side of these walls while pink noise was generated at high levels on the source side. Airborne sound flanking was still evident at the joints of the metal deck. The concrete had not filled the joints as expected.

Wherever they were accessible, these joints were caulked on each side of the wall, from the wall out for a distance of approximately one meter out from the wall. The joints occurred every 610 mm (24"). The investigation also revealed several concealed conditions where airborne sound leaks were still present.

In each case, sound leaks were identified and repaired. When conditions were found that were likely to occur in other similar units, the similar units were investigated and repaired if necessary. The walls below ASTC 45 were re-tested, and in some cases, repaired further and re-tested again. In all cases the walls were brought up to ASTC 45 or better.

5 CONCLUSIONS

Exposed metal roof deck (with lightweight roofing systems above) can reduce sound isolation between condominiums. The lack of a ceiling allows for potential airborne flanking paths that are not a problem when a ceiling is present. Joints in the metal roof deck running perpendicular to the demising walls can be a significant airborne sound leak if not sealed properly. This can occur whether or not there is concrete on top of the metal deck. Structural penetrations of the wall can be difficult to seal properly.

Structureborne flanking through the exposed metal roof deck can severely limit the sound isolation between spaces. Our tests indicate that structureborne flanking through the roof deck reduced the design rating by up to 17 ASTC points. The largest reduction in Apparent

Transmission Loss occurred at 630 Hz and 800 Hz for a 76 mm deep composite metal deck. The ribs of the deck radiated sound at 630 Hz and 800 Hz, while the flat upper surface of the deck radiates at lower frequencies. A narrow concrete strip poured perpendicular to the ribs of the deck can damp vibration and reduce the radiated sound. The thin strip of concrete likely provides less sound reduction than a concrete slab over the entire roof.

6 ACKNOWLEDGEMENTS

The Author wishes to thank David Manley, Mick Barnhardt, and Jessica Triggs of D. L. Adams Associates, Inc., for their assistance with the preparation of this paper.

7 REFERENCES

1. Jim X. Borzys, P.E., "Flanking noise transmission in condominiums via steel roof deck", Proceedings of NOISE-CON 2010, Institute of Noise Control Engineering, (2010).
2. István L. Vér and Douglas H. Sturz, "Structureborne Sound Isolation", Chapter 32 in *Handbook of Acoustical Measurements and Noise Control*, 3rd Edition, edited by Cyril M. Harris, Acoustical Society of America, New York, (1998).

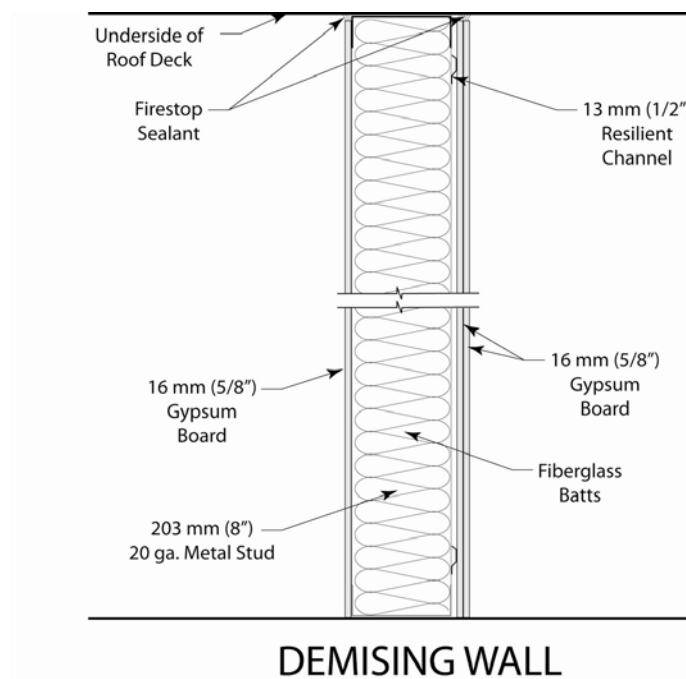

Fig. 1 - Demising wall construction.

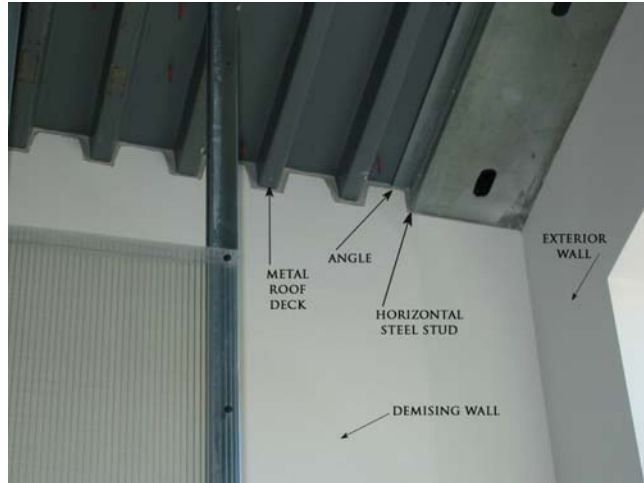

Fig. 2 - Photograph of horizontal stud.

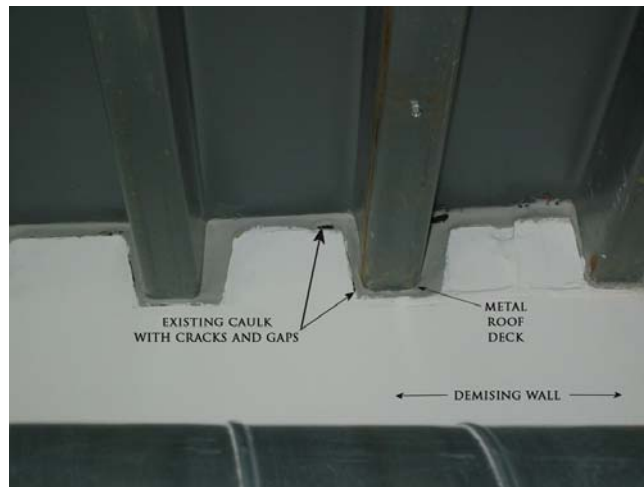

Fig. 3 - Photograph of joint between wall and roof deck.

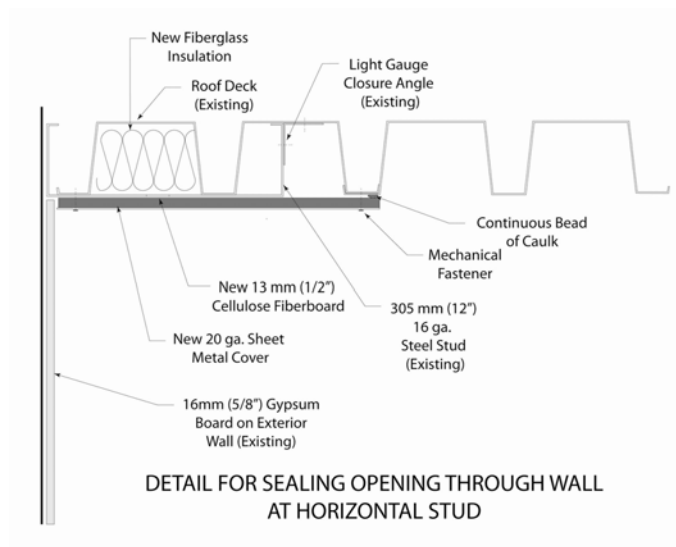

Fig. 4 - Detail to seal wall at horizontal stud.

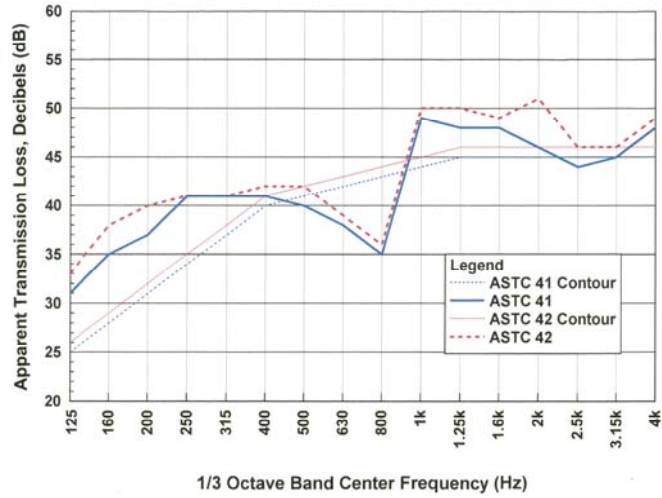

Fig. 5 - ASTC test results.

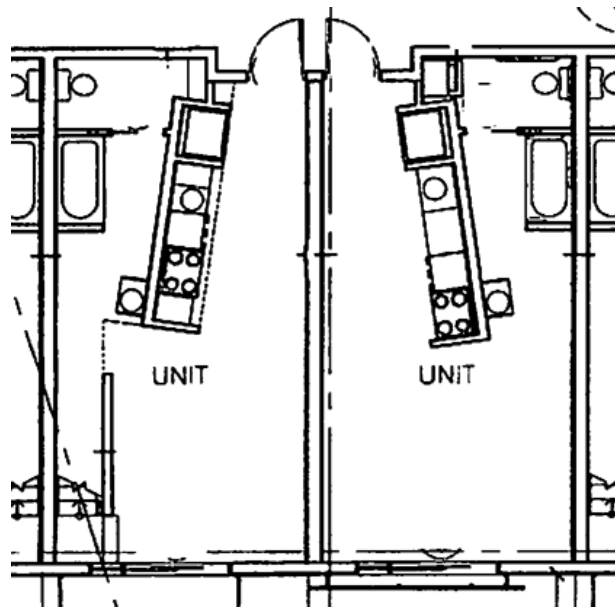

Fig. 6 - Floor plan of test units.

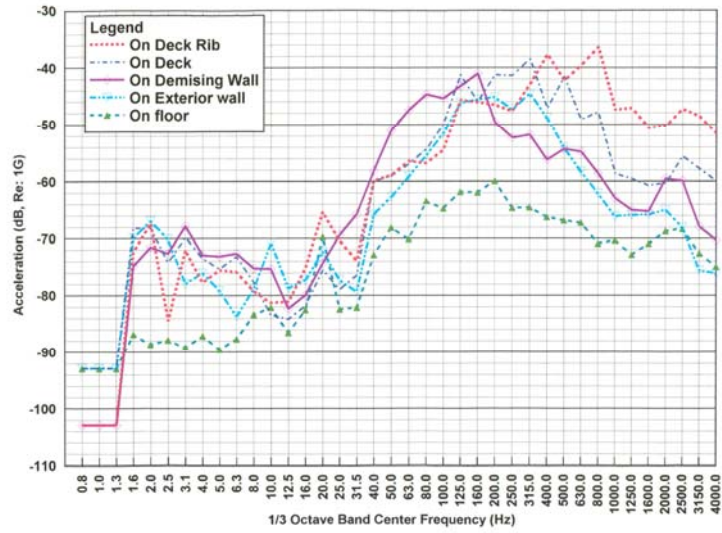

Fig. 7 - Vibration measurements.

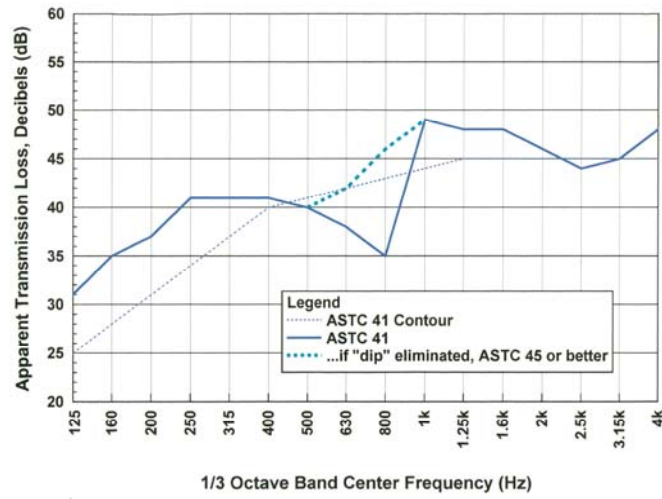

Fig. 8 - ASTC estimate if "dip" eliminated.

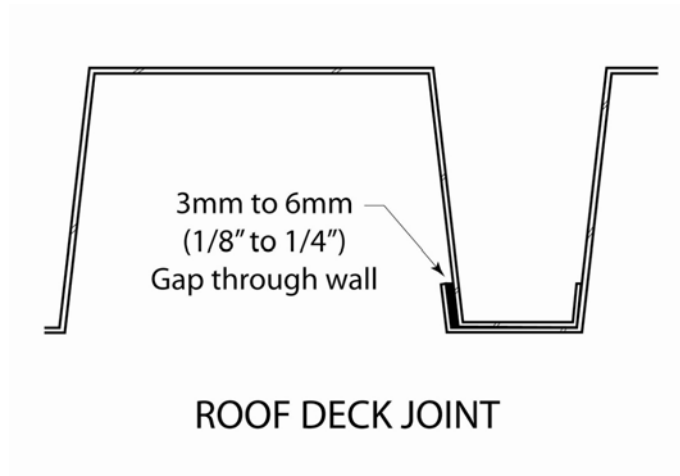

Fig. 9 - Detail of joint in metal roof deck.

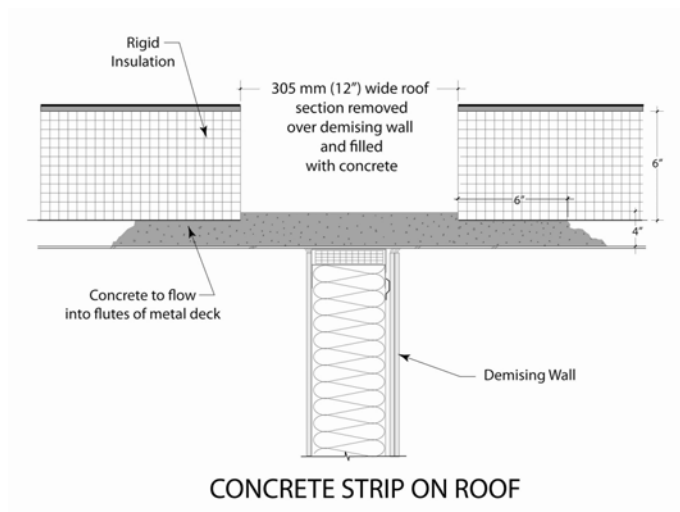

Fig. 10 - Concrete strip detail.

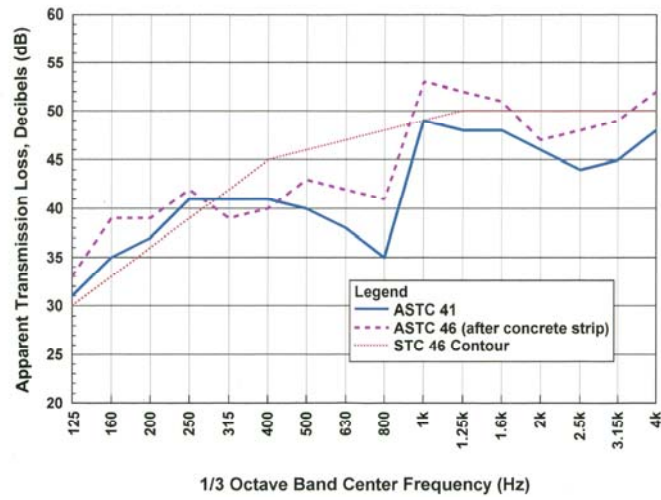

Fig. 11 -ASTC test results, before and after concrete strip.



Fig. 12 - Vibration measurements after concrete strip installed.